





Endo-Model – M

Modular Knee Prosthesis System
with Segmental Bone Replacement Components

CE 0482

Explanation of Pictograms			
	Manufacturer		Article number
	Material number		Product meets the applicable requirements, which are regulated in the EU harmonization legislation for the affixing of the CE marking.

Endo-Model – M

Modular Knee Prosthesis System with Segmental Bone Replacement Components

02	System Description
	Assembly Instruction
04	• Insertion of Anti-luxation Device
05	• Insertion of Modular Stems
06	Indications/Contraindications
	Implants
07	Measurements Joint Components
	Joint Components
08	• Rotational Version
09	• Rotational Version with LINK PorEx Surface Modification
	Joint Components
10	• Hinged Version
	LINK MEGASYSTEM-C – Endo-Model Modular Joint Components with female taper
11	• Intracondylar Version, Rotational and Hinged Version
	LINK Endo-Model EVO – W: Modular Joint Components
12	• Condylar Replacement, Rotating Hinge and Pure Hinge
13	Modular Stems, cemented
14	Modular Stems, cementless
16	Femoral Segments (UHMWPE und Tilastan-S) for Rotational and Hinged Version
22	Proximal Tibial Spacers (UHMWPE und Tilastan-S) for Rotational and Hinged Version
24	Proximal Tibial Segments (Tilastan-S) for Rotational and Hinged Version
25	Centralizers and Patella Components
26	Replacement Sets for Rotational and Hinged Version
	Instruments
28	Instrument Set for Endo-Model – M Modular Knee Prosthesis System
36	Additional Instrument Set for V02 coupling mechanism for Endo-Model – M and Rotational Knee Prosthesis Endo-Model
37	Additional Instruments
38	Accessories: X-ray Templates
39	Further Information
40	Literature
	Important Information

The **Endo-Model–M Modular Intracondylar Total Knee Joint Prosthesis** is an additional version of the **LINK Endo-Model Rotational and Hinge Knee System**.



Based on the same low friction principle, the rotational movement of this prosthesis passes smoothly through a pivot point in the physiological region. The Endo-Model – M Rotation Knee Joint Prosthesis permits flexion of the joint up to 142°. Due to the special shape of the tibial contact surfaces and physiological rotation, the kinematics of this prosthesis allow for cushioned transmission of force. The Hinge Knee Prosthesis permit only flexion of the joint up to 142°, without rotation.

With every step, and especially when falling, torsional stresses are transmitted to the prosthetic anchorage which adversely affects the longevity of the cement interface. The cushioned transmission of forces, made possible by the design features, provides a dampened impact upon the boundary layer of the cement interface. The resection required during implantation of the Endo-Model – M Knee Joint Prosthesis amounts to only 14 mm in the tibia-femur joint plane. With the medium sized intracondylar component only 30 mm wide, there is usually ample bone mass left in the event a revision is necessary. Normally, the resection is smaller compared with a Total Knee implant. Design and dimensioning of the

Rotation Knee Joint Prosthesis significantly simplify the surgical procedure. Mounting of the femoral and tibial components is a simple task, requiring only one special introducer instrument for the UHMWPE Plateau. Both components are linked by the special anti-luxation device of the plateau without reducing the motional and rotational sequences. Implantation is facilitated by a small number of easily manipulated instruments. The Hinge Knee Prosthesis is linked by an axis mechanism.

Flexion and rotation of the knee prosthesis occurs in a cross joint. Hyperextension amounts to 2°. The compromise axis lies in the region of the physiological pivot point. Flexion of up to 142° is possible. Often during endoprosthesis replacement of the knee joint, an advancement of the patella or of the patella bearing surface is observed. By displacing the femoral component dorsally relative to the tibial axis, the natural range of motion is also preserved in the patello-femoral joint. This protects against progression of retropatellar arthrosis. Rotation of the prosthesis terminates in the extended position by form closure and assures a secure posture. The rotational option increases continuously with flexion. This rotation is

limited primarily by the capsule ligament apparatus. The body weight, bearing on the joint, elastically dampens further rotation. The femoral component of the Endo-Model – M Total Knee Joint Prosthesis has a normal valgus position of 6°.

Both prosthesis components are broadly supported on the respective knee joint surfaces so that the compression strength of the cancellous bone in the femur and tibia, is not exceeded. The flanges of the femoral component are anatomically shaped. Its ventral depression provides a smooth transition from the implant to the trochlear groove.

The modular prosthesis stems are available in cemented and cementless versions (with smooth surface or longitudinal ribs respectively). To achieve a central position within the medullary canal, the tips of the cemented stems are fitted with star shaped UHMWPE caps. Direct contact of the metal stem with the inner wall of the bone is thereby prevented.

The stems are supplied in lengths of 50 up to 280 mm. Special femoral segments for revision surgery of resurfacing knee implants (reconstruction of condyles) and for tumor cases are also available. It is absolutely necessary to use these segments only in combination with longer stem.

LINK PorEx (TiNbN = Titanium Niobium Nitride) Surface modification

The hypoallergenic LINK PorEx surface modification leads to a ceramic-like surface, which significantly reduces the release of ions and can improve tolerance in patients who are sensitive to metal¹.

This surface is extremely hard and possesses abrasion properties similar to those of ceramics. These qualities and the wetting angle of the surface give it a low friction coefficient when in contact with fluids.

¹ Internal Study of the influence of TiNbN-coating on the ion release of CoCrMo-alloys in SBF buffer simulator testing.



Insertion of Anti-luxations Device



After cementation of tibial and femoral components the UHMWPE plateau is removed from the tibial tray by loosening the trial screw. With the knee in flexion both components are assembled.

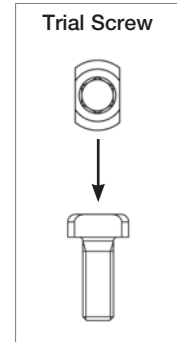

The tibial plateau is attached to the introducer and slid between the femoral and tibial components so that its medial lip grabs over the flange of the femoral bushing. Care must be taken that the dovetailed medial and lateral parts fit into the groove at the posterior rim of the metal tibial tray (fig. B).

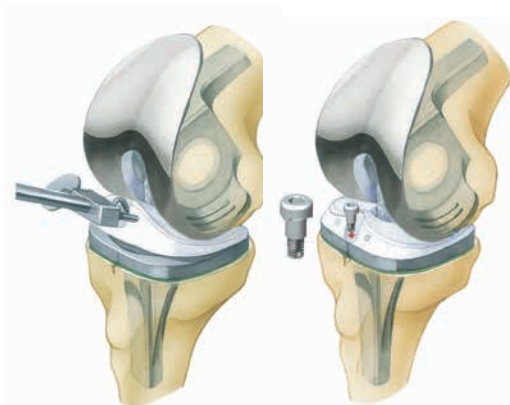
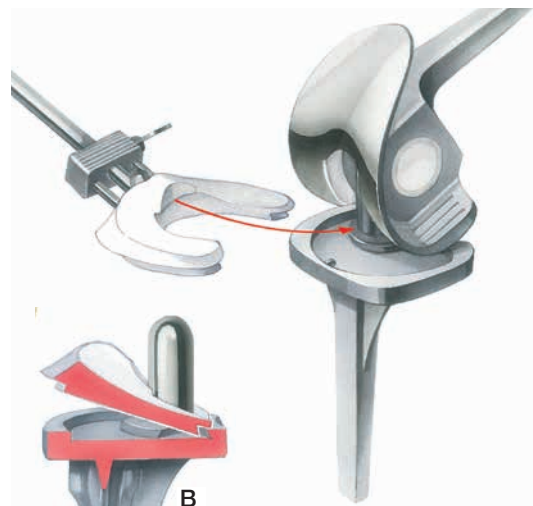

In this position the UHMWPE plateau is pressed down into the metal tray and firmly fixed by the self-locking screw.

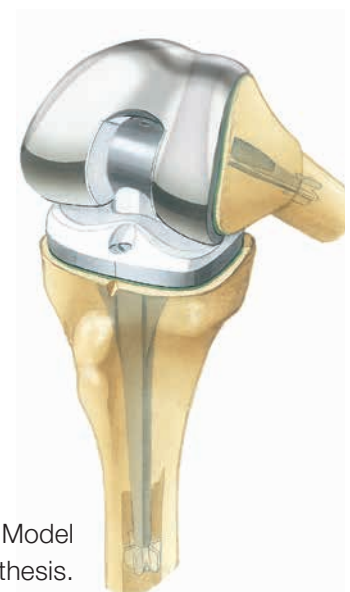

Implanted Endo-Model Modular Knee Prosthesis.

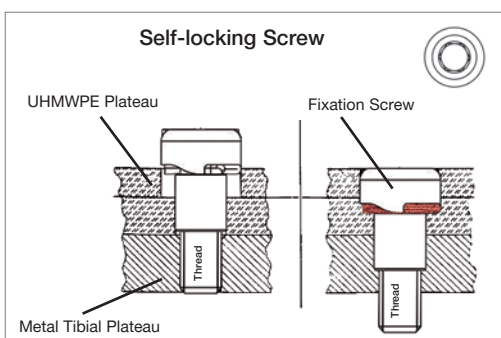

Insertion of Modular Stems



The modular stems are joined by a cone assembly. To ensure rotational stability, the stem has two opposing flanges which are inserted in the medial and lateral grooves on the femoral / tibial components.

The current version V02 features a 6 mm groove for attachment of modular stems with female taper and flanges of 3 mm or 6 mm. When attaching modular stems with 3 mm flanges, the stem must be orientated on the taper so that the threaded hole for the counter screw is not obscured (A). To this end, the alignment aid (15-6096/00) for modular stems is used (B). Modular stems with 6 mm flanges cannot be combined with Endo-Model implants with 3 mm grooves.



By tightening the locking screw (2) located in the taper (3) of the tibial respectively femoral component its pointed tip presses the stem (1) firmly onto the taper. A counter screw (4) secures the stem locking screw against loosening. The screw fixation is performed medially. **Screws are only to be tightened hand-tight.**

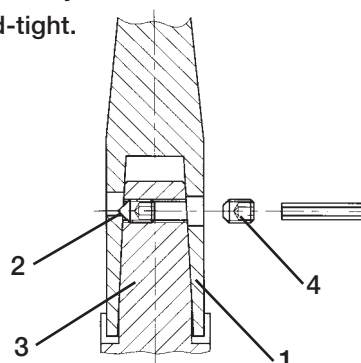
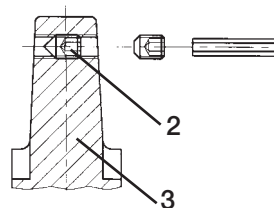

Counter Screw



Indications/Contraindications

Note:

Specified indications/contraindications see catalog:

718en_Endo-Model –M modular Knee Prosthesis System, Surgical Technique

Measurements Joint Components

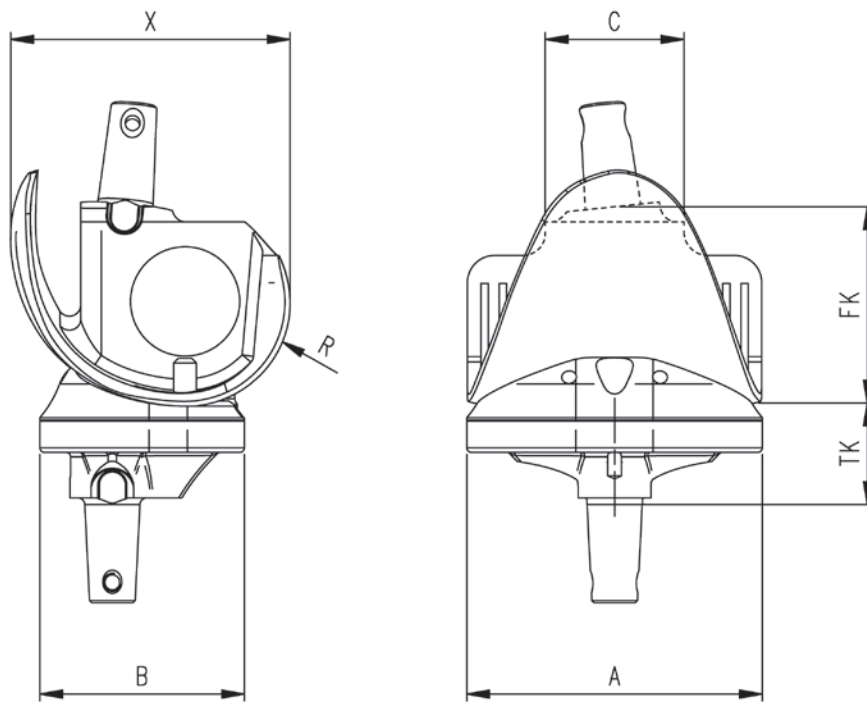

Size Version	A mm	B mm	C mm	FK mm	X mm	TK mm	R mm
x-small/right	55	42	28	39	50	22	17
x-small/left	55	42	28	39	50	22	17
small/right	60	45	30	42	57	22	20
small/left	60	45	30	42	57	22	20
medium/right	65	45	30	46	62	22	23
medium/left	65	45	30	46	62	22	23
large/right	75	48	35	50	65	22	25
large/left	75	48	35	50	65	22	25

Endo-Model – M: Modular Knee Prosthesis System, Joint Components

Rotational Version

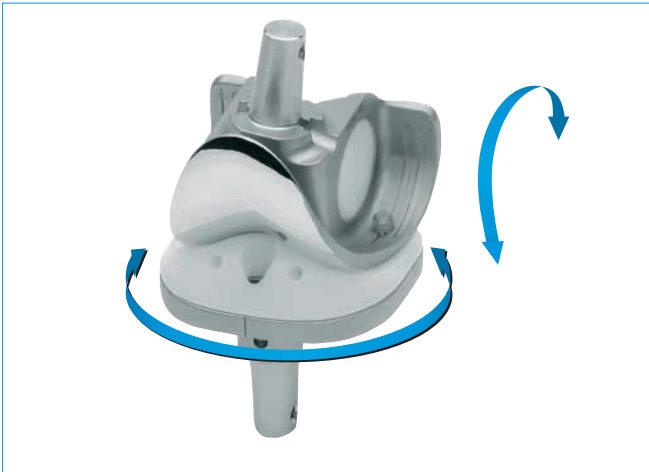

MAT EndoDur (CoCrMo), EndoDur – S (CoCrMo), UHMWPE, Tilastan-S				MAT EndoDur (CoCrMo), EndoDur – S (CoCrMo), UHMWPE, Tilastan-S			
Modular Joint Component Units consisting of: 				Femoral Components:		Tibial Components:	
REF	Size	Version	Width mm	REF	Version	REF	Version
15-2815/11	x-small	right	55	15-2810/11	right	15-2814/01	neutral
15-2815/12	x-small	left	55	15-2810/12	left		
15-2816/11	small	right	60	15-2811/11	right	15-2814/02	neutral
15-2816/12	small	left	60	15-2811/12	left		
15-2817/11	medium	right	65	15-2812/11	right	15-2814/03	neutral
15-2817/12	medium	left	65	15-2812/12	left		
15-2818/11	large	right	75	15-2813/11	right	15-2814/04	neutral
15-2818/12	large	left	75	15-2813/12	left		

Screws to secure the taper assembly between joint component and stem:

A pointed stem locking screw is already located inside the taper of each joint component (exception: single packed Tibial Components). The inside packing unit of each joint component includes a counter screw (+ replacement screw) to secure the stem locking screw.

Required: Additional Instrument Set V02, see page 36.

Rotational Version with LINK PorEx*

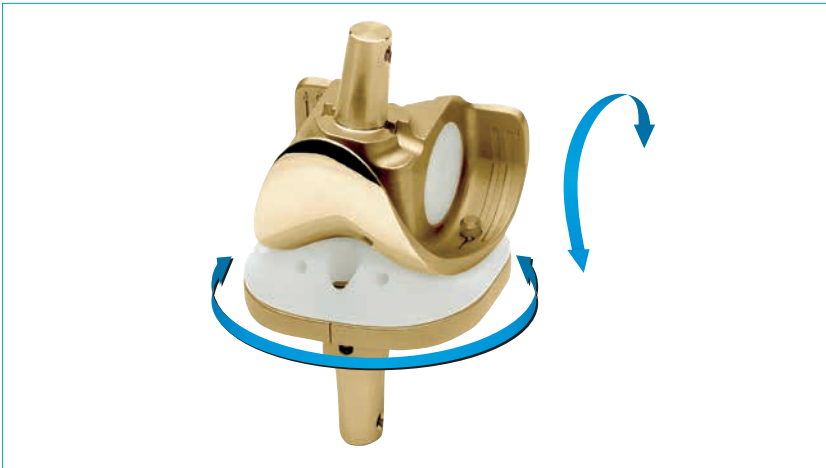

MAT EndoDur (CoCrMo)/LINK PorEx*, EndoDur – S (CoCrMo), UHMWPE, Tilastan-S			
Modular Joint Component Units			
REF	Size	Version	Width mm
15-3815/11	x-small	right	55
15-3815/12	x-small	left	55
15-3816/11	small	right	60
15-3816/12	small	left	60
15-3817/11	medium	right	65
15-3817/12	medium	left	65
15-3818/11	large	right	75
15-3818/12	large	left	75

Screws to secure the taper assembly between joint component and stem:

A pointed stem locking screw is already located inside the taper of each joint component (exception: single packed Tibial Components). The inside packing unit of each joint component includes a counter screw (+ replacement screw) to secure the stem locking screw.

Replacement Sets for Rotational Tibia Plateaus, with security screw

MAT CoCrMo/LINK PorEx*, UHMWPE	
REF	Size
15-0037/17	x-small
15-0037/14	small
15-0037/15	medium
15-0037/16	large

Each package contains:

- PE plateau and PE plateau anchoring screw

Replacement Sets

MAT EndoDur – S (CoCrMo)/LINK PorEx*, UHMWPE	
REF	Size
15-3027/10	x-small
15-3027/11	small
15-3027/12	medium
15-3027/13	large

Each package contains:

- Complete coupling mechanism,
- Bearing boxes,
- PE plateau and PE plateau anchoring screw.

Required: Additional Instrument Set V02, see page 36.

* LINK PorEx: TiNbN = Titanium-Niobium-Nitride; hypoallergenic coating (gold colour).

Endo-Model – M: Modular Knee Prosthesis System, Joint Components

Hinged Version

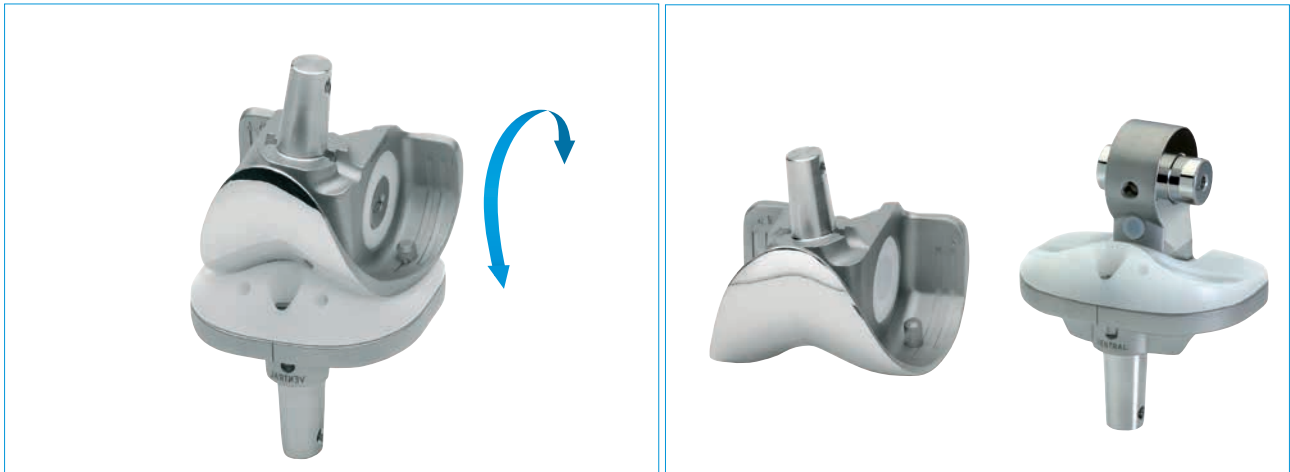

MAT EndoDur (CoCrMo), EndoDur – S (CoCrMo), UHMWPE, Tilastan-S				MAT EndoDur (CoCrMo), EndoDur – S (CoCrMo), UHMWPE, Tilastan-S			
Modular Joint Component Units consisting of:				Femoral Components:		Tibial Components:	
REF	Size	Version	Width mm	REF	Version	REF	Version
15-2835/11	x-small	right	55	15-2830/11	right	15-2834/01	neutral
15-2835/12	x-small	left	55	15-2830/12	left	15-2834/02	neutral
15-2836/11	small	right	60	15-2831/11	right	15-2834/03	neutral
15-2836/12	small	left	60	15-2831/12	left	15-2834/04	neutral
15-2837/11	medium	right	65	15-2832/11	right		
15-2837/12	medium	left	65	15-2832/12	left		
15-2838/11	large	right	75	15-2833/11	right		
15-2838/12	large	left	75	15-2833/12	left		

Screws to secure the taper assembly between joint component and stem:

A pointed stem locking screw is already located inside the taper of each joint component (exception: single packed Tibial Components). The inside packing unit of each joint component includes a counter screw (+ replacement screw) to secure the stem locking screw.

LINK MEGASYSTEM-C: Endo-Model Modular Joint Components with female taper, Intracondylar Version

Rotational Version



MAT CoCrMo, UHMWPE, Tilastan-S						
Units consisting of:			Femoral Components:		Tibial Components:	
REF	Size	Version	REF	Width mm	REF	Width mm
15-8521/25	small	right	15-8521/26	60	15-2814/02	60
15-8521/27	small	left	15-8521/28	60		
15-8521/29	medium	right	15-8521/30	65	15-2814/03	65
15-8521/31	medium	left	15-8521/32	65		
15-8521/33	large	right	15-8521/34	75	15-2814/04	75
15-8521/35	large	left	15-8521/36	75		

The joint components are equipped with an anti-luxation device. Femoral components feature female tapers.

Hinge Knee Version



MAT CoCrMo, UHMWPE, Tilastan-S					
Femoral Components				Tibial Components	
REF	Size	Version	Width mm	REF	Width mm
15-8551/26	small	right	60	15-2834/02	60
15-8551/28	small	left	60		
15-8551/30	medium	right	65	15-2834/03	65
15-8551/32	medium	left	65		
15-8551/34	large	right	75	15-2834/04	75
15-8551/36	large	left	75		

LINK Endo-Model EVO – W: Modular Joint Components, Condylar Replacement

Rotating Hinge

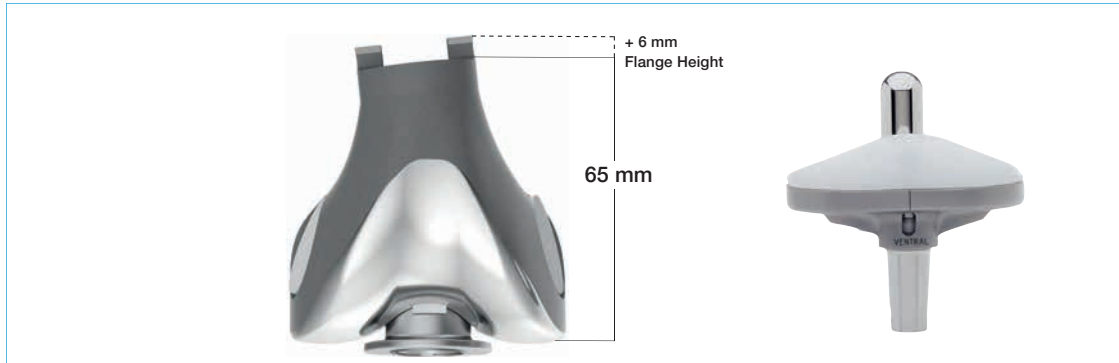

Femoral Components				Tibial Components	
REF	Size	Version	Width mm	REF	Width mm
15-8541/06	small (S)	right	60	15-2814/02	60
15-8541/08	small (S)	left	60		
15-8541/10	medium (M)	right	65	15-2814/03	65
15-8541/12	medium (M)	left	65		
15-8541/14	large (L)	right	75	15-2814/04	75
15-8541/16	large (L)	left	75		

The joint components are equipped with an anti-luxation device. Femoral components feature female tapers.

Pure Hinge

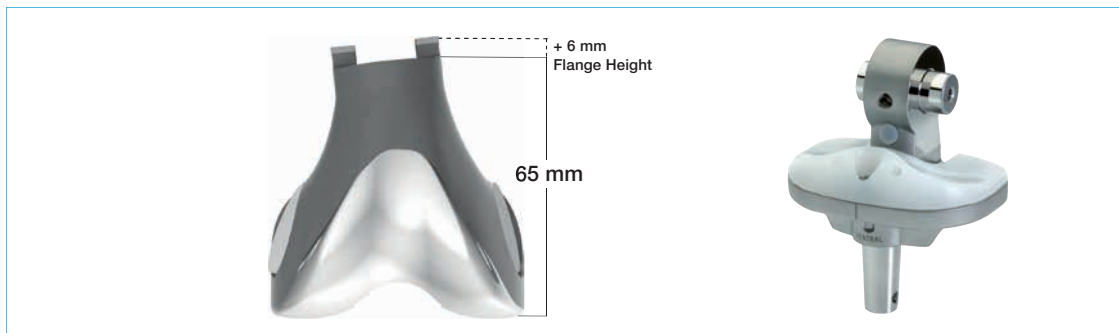

Femoral Components				Tibial Components	
REF	Size	Version	Width mm	REF	Width mm
15-8561/06*	small (S)	right	60	15-2834/02	60
15-8561/08*	small (S)	left	60		
15-8561/10	medium (M)	right	65	15-2834/03	65
15-8561/12	medium (M)	left	65		
15-8561/14	large (L)	right	75	15-2834/04	75
15-8561/16	large (L)	left	75		

* Flexion 125°

Endo-Model – M: Modular Stems, cemented

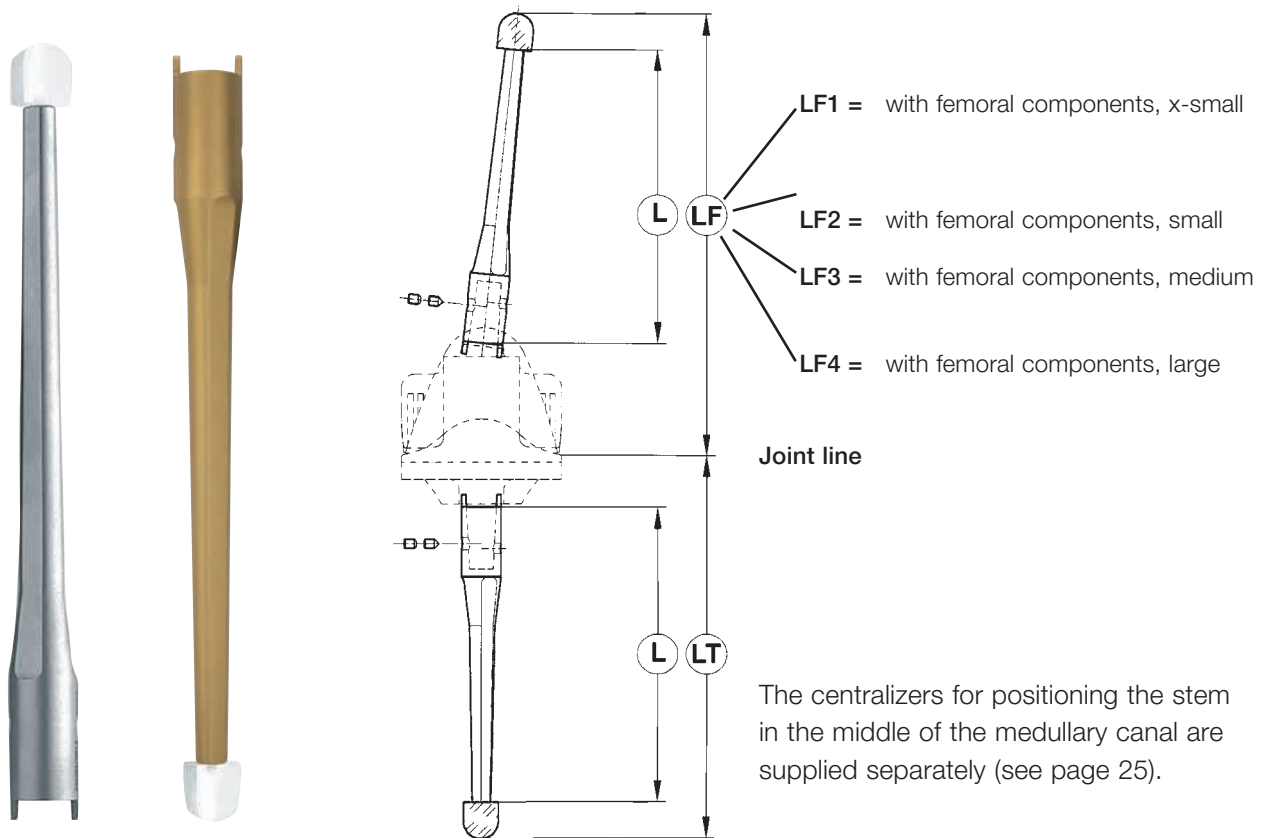

The centralizers for positioning the stem in the middle of the medullary canal are supplied separately (see page 25).

Cemented

[MAT] EndoDur – S (CoCrMo), EndoDur – S (CoCrMo)/LINK PorEx*							
[REF]	[REF]	L mm	Assembly length**				
			Tibia LT mm	Femur			
EndoDur – S (CoCrMo)	EndoDur – S (CoCrMo)/ LINKPorEx*			LF1 mm	LF2 mm	LF3 mm	LF4 mm
15-2950/01	15-3950/01	50	87	104	107	111	114
15-2950/02	15-3950/02	80	117	134	137	141	144
15-2950/03	15-3950/03	95	132	149	152	156	159
15-2950/04	15-3950/04	120	157	174	177	181	184
15-2950/05	15-3950/05	135	172	189	192	196	199
15-2950/06	15-3950/06	160	197	214	217	221	224
15-2950/07	15-3950/07	200	237	254	257	261	264
15-2950/08	15-3950/08	240	277	294	297	301	304
15-2950/09	15-3950/09	280	317	334	337	341	344

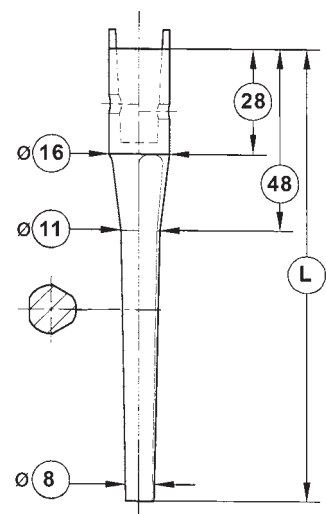

* LINK PorEx: TiNbN = Titanium Niobium Nitride; hypoallergenic coating (gold colour).

** Assembly length incl. centralizers to unit joint line

Endo-Model – M: Modular Stems, cementless

Cementless, conical

MAT Tilastan – S						
REF	L mm	Tibia LT mm	Assembly length			
			LF1 mm	LF2 mm	LF3 mm	LF4 mm
15-2952/01	50	72	89	92	96	99
15-2952/02	80	102	119	122	126	129
15-2952/03	95	117	134	137	141	144
15-2952/04	120	142	159	162	166	169
15-2952/05	135	157	174	177	181	184
15-2952/06	160	182	199	202	206	209
15-2952/07	200	222	239	242	246	249
15-2952/08	240	262	279	282	286	289
15-2952/09	280	302	319	322	326	329

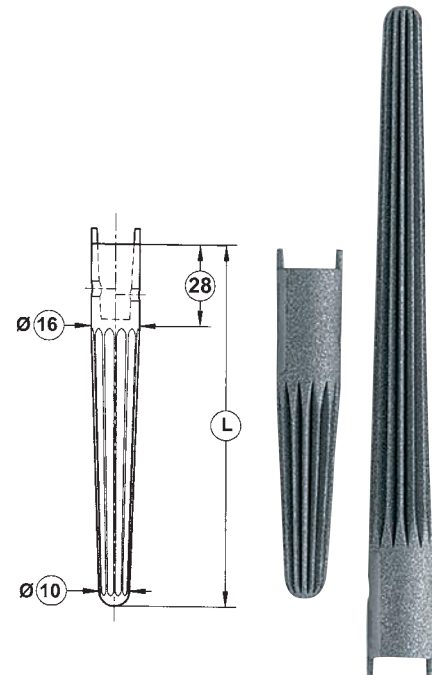

Cementless, cylindrical

MAT Tilastan – S								
REF	L mm	Ø A mm	Ø K mm	Assembly length				
				Tibia LT mm	LF1 mm	LF2 mm	LF3 mm	LF4 mm
15-2951/01	60	10	16	82	99	102	102	109
15-2951/02	60	12	16	82	99	102	102	109
15-2951/03	60	14	16	82	99	102	102	109
15-2951/04	60	16	16	82	99	102	102	109
15-2951/05	60	18	18	82	99	102	102	109
15-2951/06	120	12	16	142	159	162	162	169
15-2951/07	120	14	16	142	159	162	162	169
15-2951/08	120	16	16	142	159	162	162	169
15-2951/09	120	18	18	142	159	162	162	169
15-2951/10	160	12	16	182	199	202	202	209
15-2951/11	160	14	16	182	199	202	202	209
15-2951/12	160	16	16	182	199	202	202	209
15-2951/13	160	18	18	182	199	202	202	209
15-2951/14	200	12	16	222	239	242	242	249
15-2951/15	200	14	16	222	239	242	242	249
15-2951/16	200	16	16	222	239	242	242	249
15-2951/17	200	18	18	222	239	242	242	249
15-2951/18	240	12	16	262	279	282	282	289
15-2951/19	240	14	16	262	279	282	282	289
15-2951/20	240	16	16	262	279	282	282	289
15-2951/21	240	18	18	262	279	282	282	289
15-2951/22	280	12	16	302	319	322	322	329
15-2951/23	280	14	16	302	319	322	322	329
15-2951/24	280	16	16	302	319	322	322	329
15-2951/25	280	18	16	302	319	322	322	329

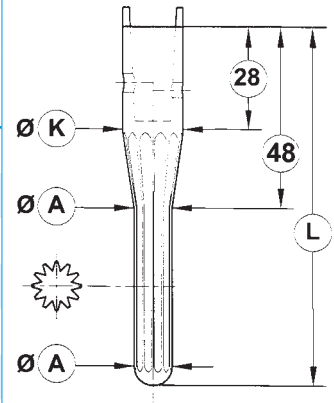

Endo-Model – M: Femoral Segments UHMWPE,
for Endo-Model Rotational and Hinged Version



Femoral Segments for femoral components: Size 1 and 2

[MAT] UHMWPE			
For Femoral Components:			
[REF]	Size	Version	Width mm
Set: Size 1 (Height 20 mm)			
15-2965/01	x-small	right	55
15-2961/01	small	right	60
15-2961/02	medium	right	65
15-2961/03	large	right	75
15-2965/10	x-small	left	55
15-2961/10	small	left	60
15-2961/11	medium	left	65
15-2961/12	large	left	75

[REF]	Side
consisting of:	
15-2965/02	medial
15-2965/03	lateral
15-2961/04	medial
15-2961/05	lateral
15-2961/06	medial
15-2961/07	lateral
15-2961/08	medial
15-2961/09	lateral
15-2965/12	medial
15-2965/13	lateral
15-2961/14	medial
15-2961/15	lateral
15-2961/16	medial
15-2961/17	lateral
15-2961/18	medial
15-2961/19	lateral

For Femoral Components:			
[REF]	Size	Version	Width mm
Set: Size 2 (Height 25 mm)			
15-2966/01	x-small	right	55
15-2962/01	small	right	60
15-2962/02	medium	right	65
15-2962/03	large	right	75
15-2966/10	x-small	left	55
15-2962/10	small	left	60
15-2962/11	medium	left	65
15-2962/12	large	left	75

[REF]	Side
consisting of:	
15-2966/02	medial
15-2966/03	lateral
15-2962/04	medial
15-2962/05	lateral
15-2962/06	medial
15-2962/07	lateral
15-2962/08	medial
15-2962/09	lateral
15-2966/12	medial
15-2966/13	lateral
15-2962/14	medial
15-2962/15	lateral
15-2962/16	medial
15-2962/17	lateral
15-2962/18	medial
15-2962/19	lateral

Endo-Model – M: Femoral Segments Tilastan – S,
for Endo-Model Rotational and Hinged Version



Femoral Segments for femoral components: Size 1 and 2

[MAT] Tilastan – S				
For Femoral Components:				
[REF]	Size	Version	Width mm	[REF] Side
Set: Size 1 (Height 20 mm) 				consisting of:
15-2971/00	x-small	right	55	15-2971/98 medial 15-2971/99 lateral
15-2971/01	small	right	60	15-2971/04 medial 15-2971/05 lateral
15-2971/02	medium	right	65	15-2971/06 medial 15-2971/07 lateral
15-2971/03	large	right	75	15-2971/08 medial 15-2971/09 lateral
15-2971/95	x-small	left	55	15-2971/96 medial 15-2971/97 lateral
15-2971/10	small	left	60	15-2971/14 medial 15-2971/15 lateral
15-2971/11	medium	left	65	15-2971/16 medial 15-2971/17 lateral
15-2971/12	large	left	75	15-2971/18 medial 15-2971/19 lateral
For Femoral Components:				
[REF]	Size	Version	Width mm	[REF] Side
Set: Size 2 (Height 25 mm) 				consisting of:
15-2972/00	x-small	right	55	15-2972/98 medial 15-2972/99 lateral
15-2972/01	small	right	60	15-2972/04 medial 15-2972/05 lateral
15-2972/02	medium	right	65	15-2972/06 medial 15-2972/07 lateral
15-2972/03	large	right	75	15-2972/08 medial 15-2972/09 lateral
15-2972/95	x-small	left	55	15-2972/96 medial 15-2972/97 lateral
15-2972/10	small	left	60	15-2972/14 medial 15-2972/15 lateral
15-2972/11	medium	left	65	15-2972/16 medial 15-2972/17 lateral
15-2972/12	large	left	75	15-2972/18 medial 15-2972/19 lateral

Endo-Model – M: Femoral Segments UHMWPE,
for Endo-Model Rotational and Hinged Version

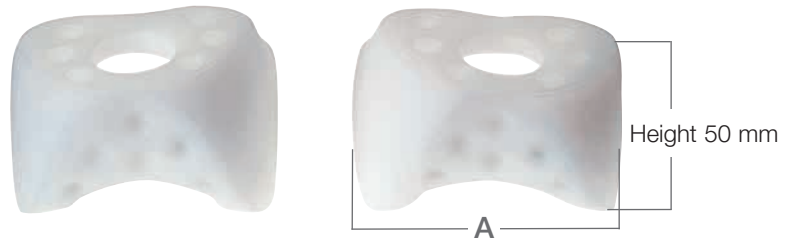

Femoral Segments, size 3*

MAT UHMWPE							
REF	Version	A mm	For Femoral Components:		A mm	Version	REF
			Size	Width mm			
Size 3* (Height 50 mm)							
15-2967/01	right	55	x-small	55	55	left	15-2967/10
15-2963/01	right	60	small	60	60	left	15-2963/02
15-2963/03	right	65	medium	65	65	left	15-2963/04
15-2963/05	right	75	large	75	75	left	15-2963/06

* Only to be used in combination with longer stems (stem length above segments approx. 180 mm).
Not compatible with LINK MEGASYSTEM-C – Modular Joint Components Endo-Model with female taper.

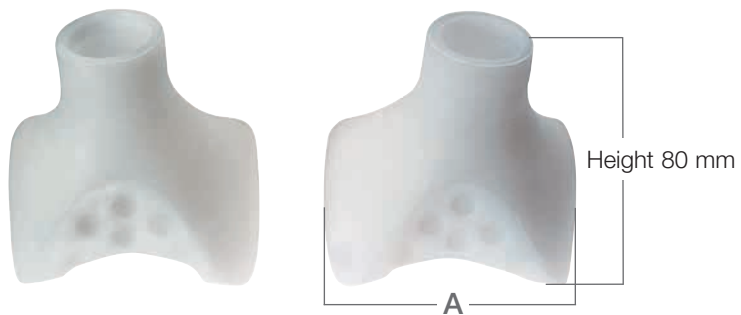

Femoral Segments, size 4*

MAT UHMWPE							
REF	Version	A mm	For Femoral Components:		A mm	Version	REF
			Size	Width mm			
Size 4* (Height 80 mm)							
15-2964/99	right	55	x-small	55	55	left	15-2964/00
15-2964/01	right	60	small	60	60	left	15-2964/02
15-2964/03	right	65	medium	65	65	left	15-2964/04
15-2964/05	right	75	large	75	75	left	15-2964/06

* Only to be used in combination with longer stems (stem length above segments approx. 180 mm).
Not compatible with LINK MEGASYSTEM-C – Modular Joint Components Endo-Model with female taper.

Endo-Model – M: Femoral Segments UHMWPE,
for Endo-Model Rotational and Hinged Version



Femoral Stem Segments*

(only to be used in combination with size 4)

MAT UHMWPE		
REF	Height mm	Size
15-2970/10	10	1
15-2970/20	20	2

* Not compatible with LINK MEGASYSTEM-C – Modular Joint Components Endo-Model with female taper.

Endo-Model – M: Femoral Segments Tilastan,
for Endo-Model Rotational and Hinged Version

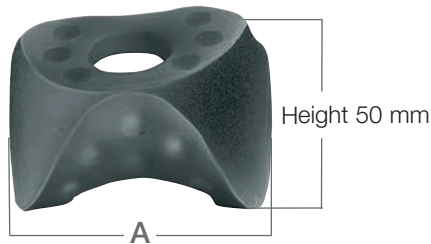

Femoral Segments, Size 3*

[MAT] Tilastan, UHMWPE							
[REF]	Version	A mm	For Femoral Components:		A mm	Version	[REF]
			Size	Width mm			
Size 3* (Height 50 mm)							
15-2973/99	right	55	x-small	55	55	left	15-2973/00
15-2973/01	right	60	small	60	60	left	15-2973/02
15-2973/03	right	65	medium	65	65	left	15-2973/04
15-2973/05	right	75	large	75	75	left	15-2973/06

* Only to be used in combination with longer stems (stem length above segments approx. 180 mm).
Not compatible with LINK MEGASYSTEM-C – Modular Joint Components Endo-Model with female taper.

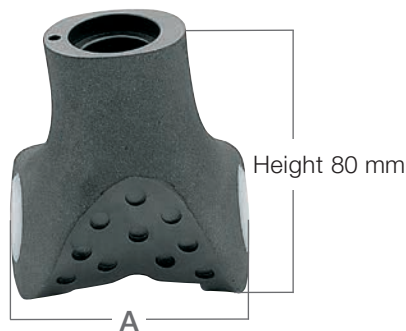

Femoral Segments, Size 4*

[MAT] Tilastan, UHMWPE							
[REF]	Version	A mm	For Femoral Components:		A mm	Version	[REF]
			Size	Width mm			
Size 4* (Height 80 mm)							
15-2976/01	right	55	x-small	55	55	left	15-2976/02
15-2977/01	right	60	small	60	60	left	15-2977/02
15-2978/01	right	65	medium	65	65	left	15-2978/02
15-2979/01	right	75	large	75	75	left	15-2979/02

* Only to be used in combination with longer stems (stem length above segments approx. 180 mm).
Not compatible with LINK MEGASYSTEM-C – Modular Joint Components Endo-Model with female taper.

Endo-Model – M: Femoral Segments Tilastan – S,
for Endo-Model Rotational and Hinged Version



Distal Femoral Segments *

(only to be used in combination with size 4)

MAT Tilastan – S		
REF	Height mm	for size
15-2976/10	10	x-small
15-2976/20	20	x-small
15-2976/40	40	x-small
15-2976/60	60	x-small
15-2976/80	80	x-small
15-2977/10	10	small
15-2977/20	20	small
15-2977/40	40	small
15-2977/60	60	small
15-2977/80	80	small
15-2978/10	10	medium
15-2978/20	20	medium
15-2978/40	40	medium
15-2978/60	60	medium
15-2978/80	80	medium
15-2979/10	10	large
15-2979/20	20	large
15-2979/40	40	large
15-2979/60	60	large
15-2979/80	80	large

* Not compatible with LINK MEGASYSTEM-C – Modular Joint Components Endo-Model with female taper.

Endo-Model – M: Proximal Tibial Spacers UHMWPE,
for Endo-Model Rotational and Hinged Version

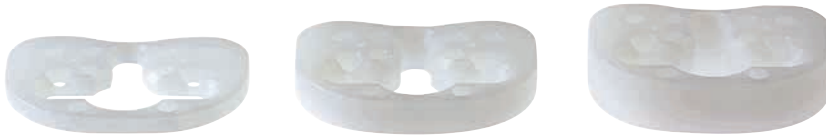

Proximal Tibial Spacers - straight -

[MAT] UHMWPE				
[REF]	Size	[REF]	Size	Height mm
Set: →		consisting of:		
15-2516/70	x-small	15-2516/55	x-small	5
		15-2516/60	x-small	10
		15-2516/65	x-small	15
15-2516/29	small	15-2516/05	small	5
		15-2516/10	small	10
		15-2516/15	small	15
15-2517/29	medium	15-2517/05	medium	5
		15-2517/10	medium	10
		15-2517/15	medium	15
15-2519/29	large	15-2519/05	large	5
		15-2519/10	large	10
		15-2519/15	large	15

*** Important Information:**
Proximal tibial spacers – straight – must not be combined with each other!

Proximal Tibial Spacers - anatomical -

[MAT] UHMWPE, EndoDur – S (CoCrMo)			
[REF]	Size	A Width mm	B Width mm
15-2516/24	x-small	55	40
15-2516/25	small	60	40
15-2517/26	medium	65	45
15-2519/27	large	75	55

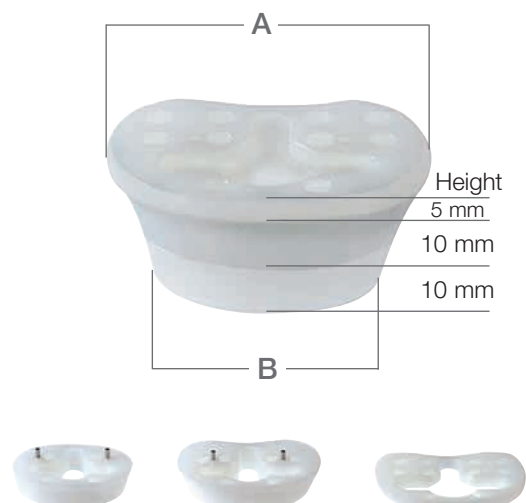

Endo-Modell – M: Proximal Tibial Spacers Tilastan – S,
for Endo-Model Rotational and Hinged Version



Proximal Tibial Spacers, full

right and left, incl. 2 hexagon socket countersunks with flat head screw 2.5 mm, for lateral and medial application.

MAT Tilastan – S		
REF	Size	H Height mm
15-2615/05	x-small	5
15-2615/10	x-small	10
15-2615/15	x-small	15
15-2616/05	small	5
15-2616/10	small	10
15-2616/15	small	15
15-2617/05	medium	5
15-2617/10	medium	10
15-2617/15	medium	15
15-2618/05	large	5
15-2618/10	large	10
15-2618/15	large	15

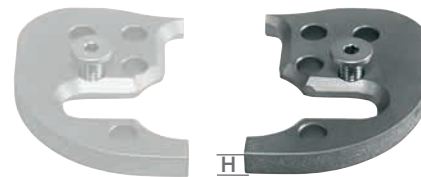

Proximal Tibial Spacers, half

incl. hexagon socket countersunks with flat head screw 2.5 mm, for lateral and medial application.

MAT Tilastan – S		
REF	Size	H Height mm
15-2990/11	x-small	5
15-2990/12	x-small	10
15-2990/13	x-small	15
15-2990/01	small	5
15-2990/04	small	10
15-2990/07	small	15
15-2990/02	medium	5
15-2990/05	medium	10
15-2990/08	medium	15
15-2990/03	large	5
15-2990/06	large	10
15-2990/09	large	15

Important Information:

Proximal tibial spacers of Tilastan must not be combined with each other!

Endo-Model – M: Proximal Tibial Segments Tilastan – S,
for Endo-Model Rotational and Hinged Version

Proximal Tibial Segments - anatomical -

MAT Tilastan – S				
REF	Size	B Width mm	h Height mm	H Height mm
15-2981/01	x-small	55	50	60
15-2982/01	small	60	50	60
15-2983/01	medium	65	50	60
15-2984/01	large	75	50	60

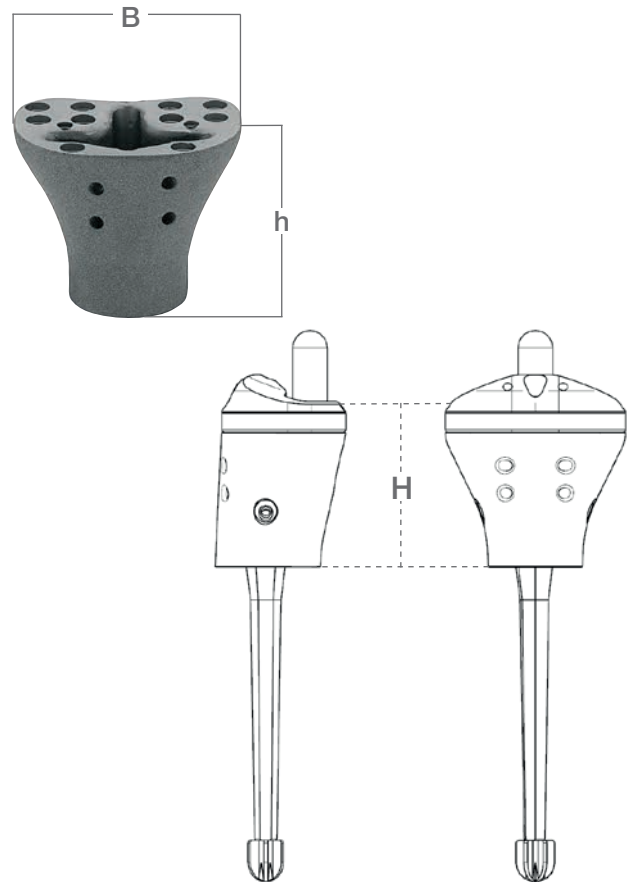

Proximal Tibial Stem Segments

MAT Tilastan – S		
REF	L Length mm	for Size
15-2981/10	10	x-small
15-2981/20	20	x-small
15-2981/40	40	x-small
15-2981/60	60	x-small
15-2982/10	10	small
15-2982/20	20	small
15-2982/40	40	small
15-2982/60	60	small
15-2983/10	10	medium
15-2983/20	20	medium
15-2983/40	40	medium
15-2983/60	60	medium
15-2984/10	10	large
15-2984/20	20	large
15-2984/40	40	large
15-2984/60	60	large



Centralizers, Patellar Components

Centralizers

MAT UHMWPE		
REF	REF	Size
Set: consisting of:		
15-2975/01	15-2975/12 15-2975/14 15-2975/16	small medium large



Ø 12 mm



Ø 14 mm



Ø 16 mm

Patellar Components central, circular

MAT UHMWPE		
REF	Size	Ø mm
15-2521/30	small	30
15-2521/35	medium	35
15-2521/40	large	40

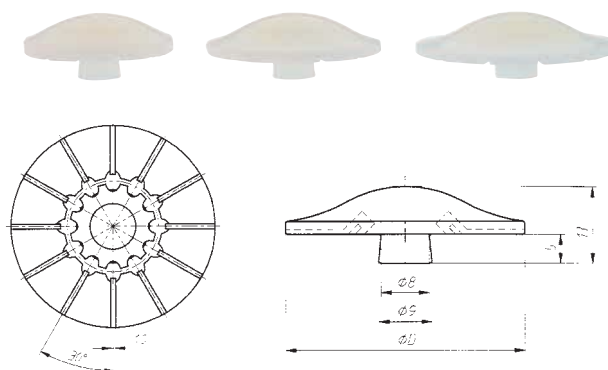

Patellar Components Endo-Model Standard/-M, 3-pegs

MAT UHMWPE			
REF	Size	Ø mm	Height mm
15-2522/30	1	30	8
15-2522/35	2	35	8
15-2522/40	3	40	8

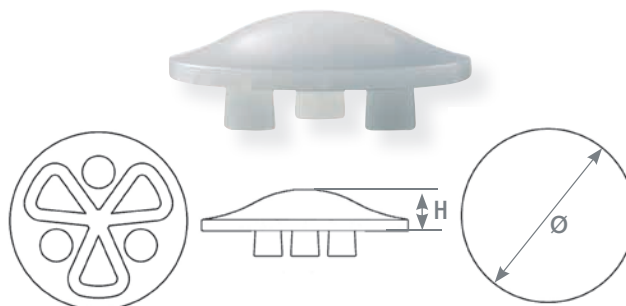

Information on instruments and surgical technique available on request.

Replacement Sets – for Endo-Model Rotational Version

**Replacement Sets
for Rotational Knee Prostheses**

MAT CoCrMo		
REF	Version	Size
15-0027/10	right/left	x-small
15-0027/11	right/left	small
15-0027/12	right/left	medium
15-0027/13	right/left	large

Each package contains:

- complete coupling mechanism,
- bearing boxes,
- PE plateau and PE plateau anchoring screw.

Required: Additional Instrument Set V02, see page 36.

**Replacement Sets
for Rotational Tibial Plateaus**

MAT UHMWPE/CoCrMo	
REF	Size
15-0027/17	x-small
15-0027/14	small
15-0027/15	medium
15-0027/16	large

Each package contains:

PE plateau and PE plateau anchoring screw.

Replacement Sets – for Endo-Model Hinged Version

Replacement Sets for Hinge Knee Prostheses, with security screw

MAT UHMWPE/CoCrMo		
REF	Version	Size
15-0027/20	right	x-small
15-0027/21	right	small
15-0027/22	right	medium
15-0027/23	right	large
15-0027/30	left	x-small
15-0027/31	left	small
15-0027/32	left	medium
15-0027/33	left	large

Each package contains:

- complete coupling mechanism,
- bearing boxes,
- PE plateau and PE plateau anchoring screw.

Replacement Sets for Hinge Knee Tibial Plateaus, with security screw

MAT UHMWPE/CoCrMo	
REF	Size
15-0027/40	x-small
15-0027/41	small
15-0027/42	medium
15-0027/43	large

Each package contains:

PE plateau and PE plateau anchoring screw.

Instrument Set for Endo-Model – M Modular Knee Prosthesis System



REF	Instrument Set, complete	
15-3200/01	Set in 7 standard containers, on 7 trays, with product illustrations and storage racks. <u>consisting of:</u>	
05-2001/03	N11 Standard Containers , empty, stainless steel, 575 x 275 x 100 mm 7 ea.	
	<u>Trays, empty, stainless steel:</u>	
15-3201/01	Tray I , 550 x 265 x 50 mm	1 ea.
15-3201/02	Tray II , 550 x 265 x 50 mm	1 ea.
15-3201/03	Tray III , 550 x 265 x 50 mm	1 ea.
15-3201/04	Tray IV , 550 x 265 x 50 mm	1 ea.
15-3201/05	Tray V , 550 x 265 x 50 mm	1 ea.
15-3201/06	Tray VI , 550 x 265 x 50 mm	1 ea.
15-3201/07	Tray VII , 550 x 265 x 50 mm	1 ea.

Tray I

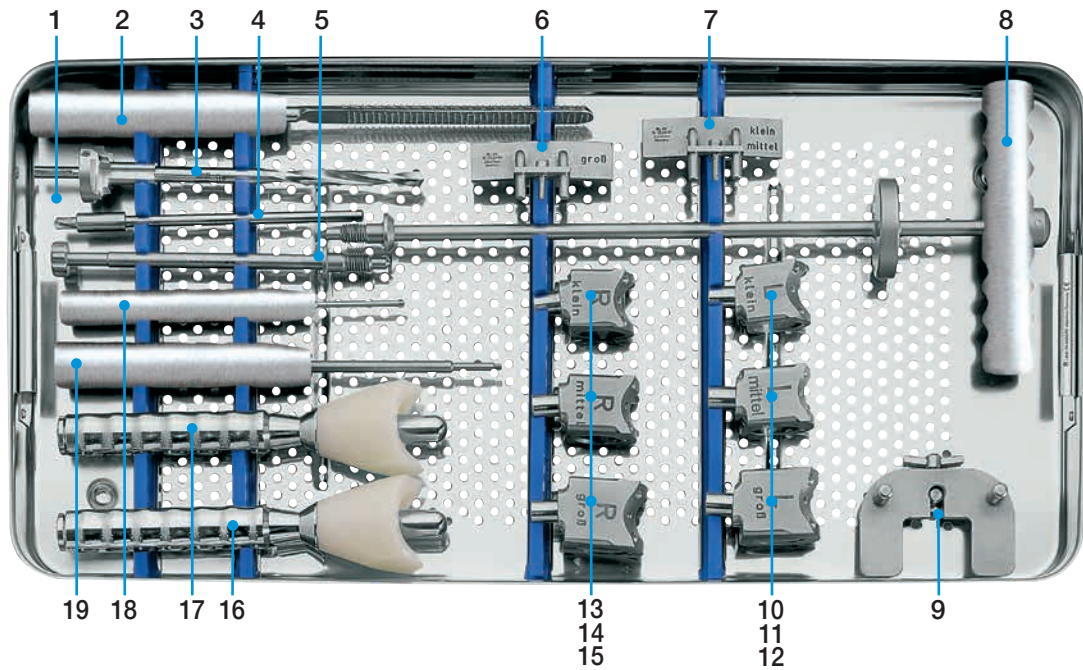

1	15-3201/01	Instrument Tray I , empty, 550 x 265 x 50 mm
2	317-643	Rasp for patella glide, 285 mm
3	15-3203/01	Drill with cutter head, femur, Ø 8 mm, with fitting: Jacobs chuck E
4	15-3202/01	Drill with stop, Ø 6 mm, with fitting: Jacobs chuck E
5	15-3203/03	Handle for femoral alignment guide, 175 mm
		Patella Glide Resection Guide,
6	15-2530/01	small + medium
7	15-2530/05	large
8	15-2534/15	Threaded Rod with handle
9	15-3203/02	Femoral Alignment Guide
		Femoral Saw Guides
10	15-3203/32	left small
11	15-3203/42	left medium
12	15-3203/52	left large
13	15-3203/31	right small
14	15-3203/41	right medium
15	15-3203/51	right large
		Impactor for femoral components
16	15-2537	small + medium
17	15-2537/02	large
18	64-1181/06	Hex Screwdriver , hex 2.0 mm, 175 mm
19	175-600	Hex Screwdriver , hex 3.0 mm, 230 mm

Tray II

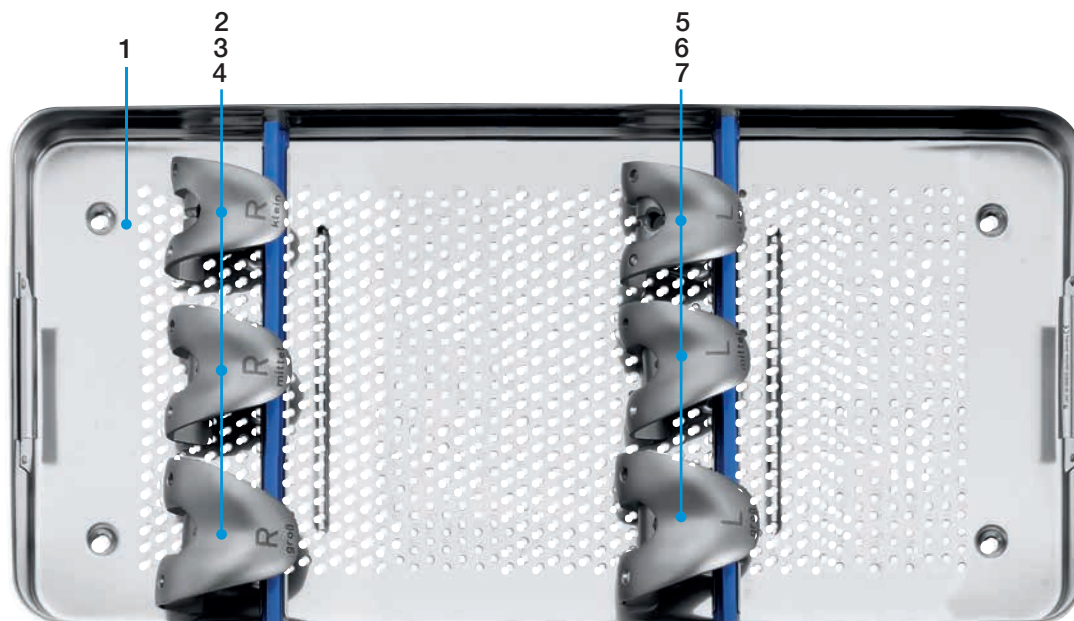

1	15-3201/02	Instrument Tray II, empty, 550 x 265 x 50 mm	
Femoral Trial Prostheses with patellar flange			
2	15-3234/07	right	small
3	15-3234/19	right	medium
4	15-3234/25	right	large
5	15-3234/08	left	small
6	15-3234/20	left	medium
7	15-3234/26	left	large

Tray III

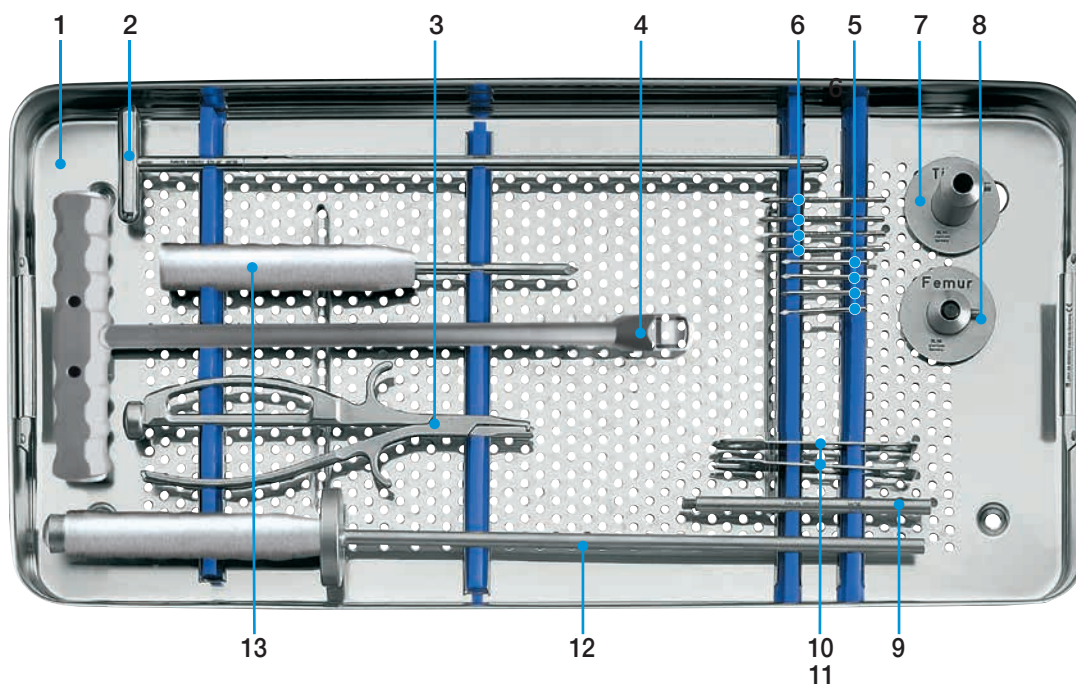

1	15-3201/03	Instrument Tray III , empty, 550 x 265 x 50 mm
2	317-623	Guide Rod , intramedullary, Ø 8 mm, 365 mm
3	317-586	Driver and Extraction Forceps , for fixation pins, 210 mm
4	130-429G	Handle for reamers and awls, square fitting dismantable, 300 mm
		Fixation Pins , Ø 3 mm
5	317-585/65	65 mm long
6	317-585/95	95 mm long
7	15-3204/10	Stop Plate , Tibia
8	15-3203/10	Stop Plate , Femur
9	15-3203/05	Extension Stem for femoral saw guides, 130 mm
10	317-656/10	Sawblade , narrow, with Synthes fitting (fittings optional)
11	317-654/10	Sawblade , wide, with Synthes fitting (fittings optional)
12	15-3202/05	Trial Stem , for femur/tibia, 450 mm
13	317-658	Bone Awl with trocar point, 215 mm

Tray IV

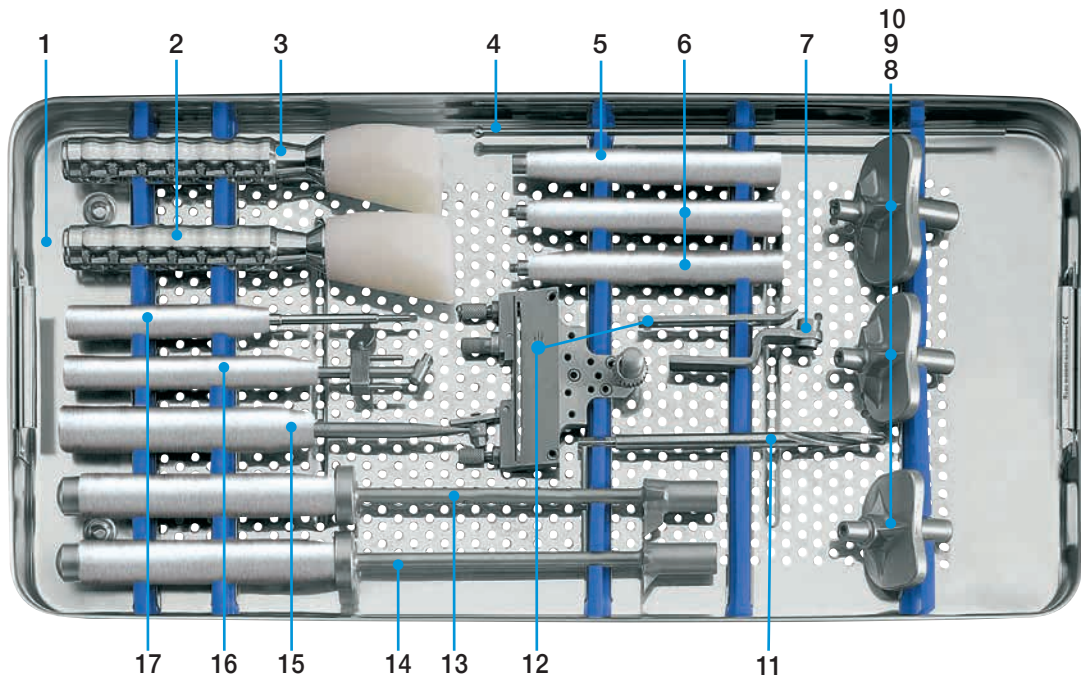

1	15-3201/04	Instrument Tray IV , empty, 550 x 265 x 50 mm
2	15-2538/10	Impactor for tibial components, small + medium
3	15-2538/12	Impactor for tibial component, large
4	317-627	Alignment Rod , extramedullary, 275 mm
5	317-648	Universal Wrench , hex 6 mm, for guide nuts, 140 mm
6	317-516/02	Handle to attach at tibial resection guide, 140 mm (contain 2 piece)
7	317-626/00	Connector for guide rod/tibial resection guide, N0°
Tibial Trial Prostheses		
8	15-3204/21	small
9	15-3204/22	medium
10	15-3204/23	large
11	317-641/08E*	Twist Drill for open femoral and tibial cavity, Ø 8 mm, 160 mm, with fitting E : Jacobs chuck
12	15-2536/50	Tibial Resection Guide , with stylus (2 parts)
13	15-3204/01	Predriver for proximal tibia, small
14	15-3204/02	Predriver for proximal tibia, medium + large
15	322-145	Screwdriver , blade width 8 mm, 210 mm
16	15-8035	Introducer for tibial plateaus
17	10-5373	Hex Screwdriver , hex 2.5 mm, 180 mm

* Fittings optional:
 B = Hudson, C = Harris, D = A-O, E = Jacobs, H = Zimmer

Tray V

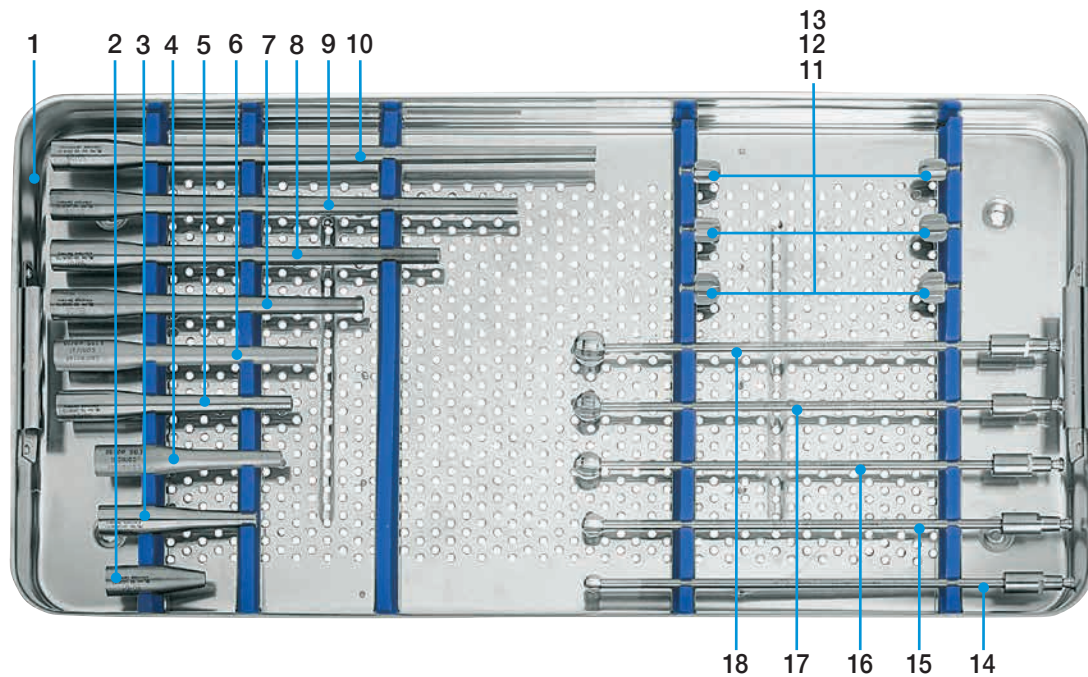

1	15-3201/05	Instrument Tray V , empty, 550 x 265 x 50 mm	
		Trial Stems for cementable prosthesis stems	
2	15-3210/05	50 mm	marking: 50/01
3	15-3210/08	80 mm	marking: 50/02
4	15-3210/95	95 mm	marking: 50/03
5	15-3210/12	120 mm	marking: 50/04
6	15-3210/13	135 mm	marking: 50/05
7	15-3210/16	160 mm	marking: 50/06
8	15-3210/20	200 mm	marking: 50/07
9	15-3210/24	240 mm	marking:: 50/08
10	15-3210/28	280 mm	marking: 50/09
		Metal Trial Centralizers (each containing 2 pieces)	
11	15-2535/12	Ø 12 mm	
12	15-2535/14	Ø 14 mm	
13	15-2535/16	Ø 16 mm	
		Ball Reamers* , 250 mm, with fitting C Harris	
14	15-1133/02C*	Ø 10 mm	
15	15-1133/03C*	Ø 12 mm	
16	15-1133/04C*	Ø 14 mm	
17	15-1133/05C*	Ø 16 mm	
18	15-1133/06C*	Ø 18 mm	

* Fittings for ball reamers optional:

B = Hudson fitting

D = A-O fitting

C = Harris fitting

E = Jacobs chuck fitting

F = Trinkle fitting

How to order: 15-1133/02B = with Hudson fitting

Tray VI

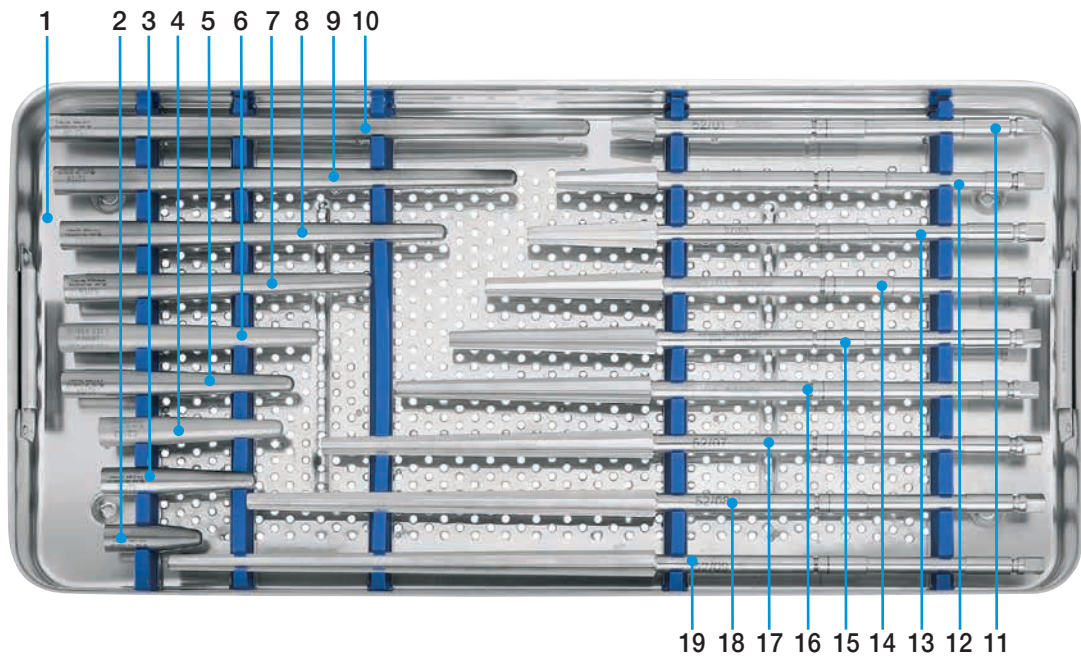

1	15-3201/06	Instrument Tray VI, empty 550 x 265 x 50 mm		
		Trial Stems, conical, for cementless prosthesis stems		
2	15-3211/05	50 mm		marking: 52/01
3	15-3211/08	80 mm		marking: 52/02
4	15-3211/95	95 mm		marking: 52/03
5	15-3211/12	120 mm		marking: 52/04
6	15-3211/13	135 mm		marking: 52/05
7	15-3211/16	160 mm		marking: 52/06
8	15-3211/20	200 mm		marking: 52/07
9	15-3211/24	240 mm		marking: 52/08
10	15-3211/28	280 mm		marking: 52/09
		Tapered Reamers, conical, for cementless prosthesis stems		
11	15-3208/05	50 mm	Total length: 220 mm	marking: 52/01
12	15-3208/08	80 mm	Total length: 250 mm	marking: 52/02
13	15-3208/95	95 mm	Total length: 265 mm	marking: 52/03
14	15-3208/12	120 mm	Total length: 290 mm	marking: 52/04
15	15-3208/13	135 mm	Total length: 307 mm	marking: 52/05
16	15-3208/16	160 mm	Total length: 330 mm	marking: 52/06
17	15-3208/20	200 mm	Total length: 370 mm	marking: 52/07
18	15-3208/24	240 mm	Total length: 410 mm	marking: 52/08
19	15-3208/28	280 mm	Total length: 450 mm	marking: 52/09

Tray VII

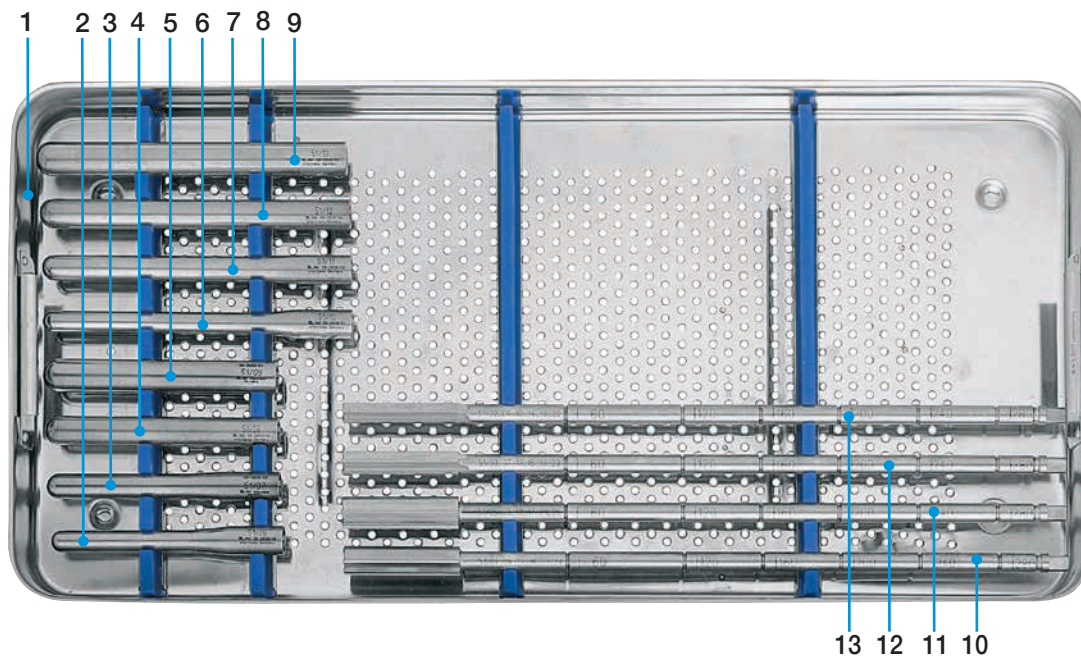

1	15-3201/07	Instrument Tray VII, empty, 550 x 265 x 50 mm	
		Trial Stems, cylindrical, for cementless prosthesis stems	
2	15-3212/12	Ø 12 x 16 mm 120 mm	marking: 51/06
3	15-3212/14	Ø 14 x 16 mm 120 mm	marking: 51/07
4	15-3212/16	Ø 16 x 16 mm 120 mm	marking: 51/08
5	15-3212/18	Ø 18 x 18 mm 120 mm	marking: 51/09
6	15-3213/12	Ø 12 x 16 mm 160 mm	marking: 51/10
7	15-3213/14	Ø 14 x 16 mm 160 mm	marking: 51/11
8	15-3213/16	Ø 16 x 16 mm 160 mm	marking: 51/12
9	15-3213/18	Ø 18 x 18 mm 160 mm	marking: 51/13
		Tapered Reamers, cylindrical, 370 mm, for cementless prosthesis stems	
10	15-3209/12	Ø 12 mm	marking: 51/02..06..10..14..18..22
11	15-3209/14	Ø 14 mm	marking: 51/03..07..11..15..19..23
12	15-3209/16	Ø 16 mm	marking: 51/04..08..12..16..18..24
13	15-3209/18	Ø 18 mm	marking: 51/05..09..13..17..18..25

Additional Instrument Set for V02 coupling mechanism
for Endo-Model– M and Rotational Knee Prosthesis Endo-Model

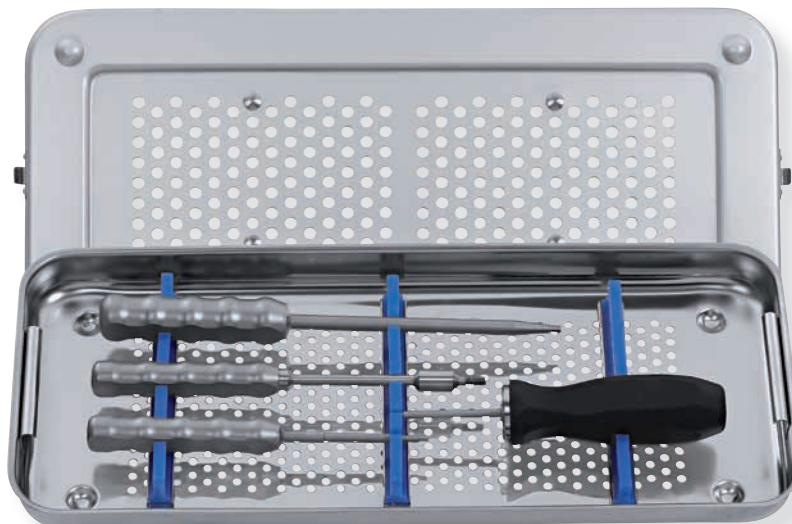

REF	Additional Instrument Set V02 (V02 coupling mechanism)
15-2529/90	Set complete , in 1 small container, on 1 tray with storage racks consisting of:
05-1000/01	Small Container K1 , empty, 460 x 190 x 92 mm
15-2529/91	Instrument Tray , empty, stainless steel, 405 x 165 x 50 mm
64-8008/02	Hex Screwdriver , with metal handle, wrench size 3.5 mm, 250 mm
15-2544	Separate Rod , for removal of the rotating bushing version V02, Ø M5, 210 mm
10-5373/01	Hex Screwdriver , with metal handle, wrench size 2.5 mm, 180 mm
15-2545	Torque Wrench , wrench size 2.5 mm, 205 mm

Additional Instruments (not included in Instrument Set)



Extractor

for modular stems with female taper, taper type 12/10 mm (for 3 mm + 6 mm noses)

REF	Length
15-0036/81	230 mm

Guide Rod with Slaphammer (without picture)

(optional for stem extraction: guide rod 317-661 in combination with driver extractor 15-8516/45 or 15-0036/81)

REF	Length
317-661	365 mm

Twist Drill (without picture)

Stainless Steel, with Jacobs Fitting (E)

REF	Length	Ø
317-641/08E	160 mm	8.0 mm

Mallet, blow-back proof (without picture)

Synthetic

REF	
16-0115/02	

15-2599/05

X-ray Templates for
Endo-Model – M
 Modular Knee Prosthesis System,
 including modular stem extensions,
 110% actual size, 1 set of 9 sheets

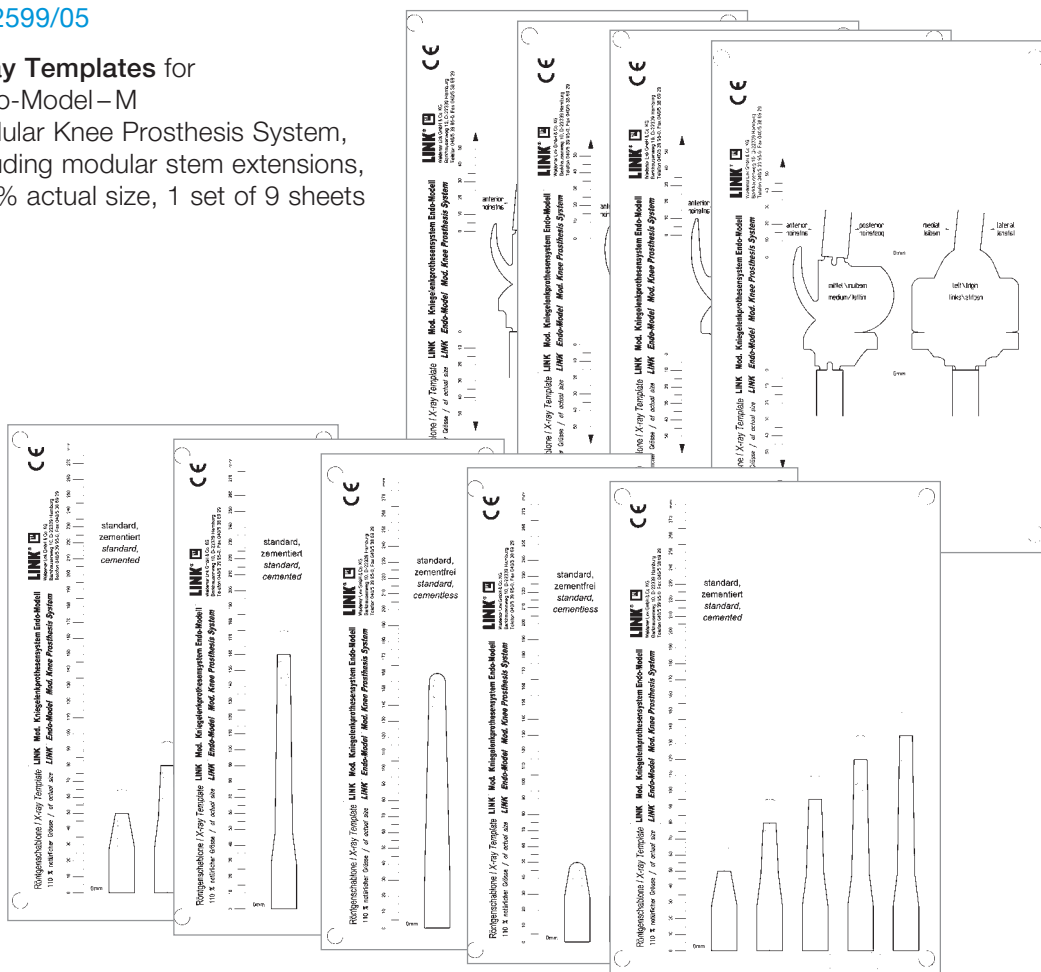

- E. Engelbrecht, A. Siegel, J. Röttger, and Prof. H. W. Buchholz*
Statistics of Total Knee Replacement: Partial and Total Knee Replacement, Design St. Georg
Journal of Clinical Orthopaedics, 1976, No. 120, pp 54-64 (K3)
- E. Engelbrecht, E. Nieder, E. Strickle, A. Keller
Intrakondyläre Kniegelenkendooprothese mit Rotationsmöglichkeit – ENDO-MODELL®
CHIRURG 52: 368-375 (1981) (K1)
- R. Dederich und L. Wolf
Kniegelenkprothesen-Nachuntersuchungsergebnisse
Unfallheilkunde (1982) 85:359-368 (K2)
- J. Röttger, K. Heinert
Die Knieendooprothesensysteme (Schlitten- und Scharnierprinzip). Beobachtungen und Ergebnisse nach 10 Jahren Erfahrung mit über 3700 Operationen.
Z. Orthop. 122(1984) 818-826 (K17)
- E. Nieder, E. Engelbrecht, A. Keller
Totale intrakondyläre Scharniergelenkendooprothese mit Rotationsmöglichkeit – Endo-Modell®
Sonderdruck aus Heft 5: Orthopädische Praxis, 1987, 23. Jahrgang, Seite 402-412 (K34)
- K. Heinert, E. Engelbrecht
Total Knee Replacement - Experience with a Surface and Total Knee Replacement: Further Development of the Model St. Georg®. 2400 Sledges and Hinges
Proceedings of the International Symposium on Total Knee Replacement, May 19-20, 1987, Nagoya, Japan Springer Verlag.; Berlin Heidelberg, New York Tokyo (1987), pp 257-273 (K53)
- E. Engelbrecht, M.D.
The Tibial Rotating Knee Prosthesis "Endo" Model: Surg. Technique
The Journal of Orthopaedic Surgical Techniques, Volume 3, Number 2, 1987 (K36)
- K. Heinert, E. Engelbrecht
Langzeitvergleich der Knie-Endoprothesensysteme St. Georg® 10-Jahres-Überlebensraten von 2236 Schlitten- und Scharnier-Endoprothesen
Der Chirurg (1988) 59:755-762 (K38)
- F. Madsen, P. Kjarsgaard-Andersen, M. Juhl, O. Sneppen
A Custom-Made Prosthesis for the Treatment of Supracondylar Femoral Fractures after Total Knee Arthroplasty: Report of Four Cases
Journal of Orthopaedic Trauma, Vol. 3, No. 4, pp. 333-337, 1989 (K42)
- E. Nieder
Schlittenprothese, Rotationsknie und Scharnierprothese Modell St. Georg® und Endo-Modell®. Differentialtherapie in der primären Kniegelenkalloarthroplastik
Orthopäde (1991) 20:170-180 (K45)
- G. von Förster, D. Klüber und U. Käbler
Mittel- bis langfristige Ergebnisse nach Behandlung von 118 periprothetischen Infektionen nach Kniegelenkersatz durch einzeitige Austauschoperationen
Orthopäde(1991) 20: 244-252 (K46)
- Adolph V. Lombardi, Jr, Thomas H. Mallory, Robert W. Eberle, and Joanne B. Adams
Results of Revision Total Knee Arthroplasty Using Constrained Prostheses
Seminars in Arthroplasty, Vol 7, No. 4 (October), 1996: pp 349-355
- E. Engelbrecht, E. Nieder, D. Klüber
Reconstruction of the Knee - Ten to Twenty Years of Knee Arthroplasty at the Endo-Klinik: A Report on the Long-term Follow-up of the St. Georg® Hinge and the Medium-term Follow-up of the Rotating Knee Endo-Model®
Springer Verlag: Tokyo, Berlin, Heidelberg, New York (1997) (K57)
- E. Nieder
Revisionsalloarthroplastik des Kniegelenks
Sonderausgabe aus: Orthopädische Operationslehre, Band III/1: Becken und untere Extremität Herausgegeben von R. Bauer, F. Kerschbaumer und S. Poisel
- F. Alt, U. Sonnekalb, N. Walker
Unikondyläre Schlittenprothese versus scharniergeführte Totalendoprothesen des Kniegelenkes
Orthopädische Praxis 1/98, 34. Jahrgang, Seite 20-24, 1998 (K61)
- A. V. Lombardi, T. H. Mallory, R. E. Eberle, J. B. Adams
Rotating Hinge Prosthesis in Revision Total Knee Arthroplasty: Indications and Results
A Reprint from Surgical Technology International VI, 1998 (K55)
- E. Nieder, G.W. Baars, A. Keller
Totaler Tibia-Ersatz Endo-Modell®
Orthopädie Aktuell: Nr. 5/1998, LINK News (K60)
- S. Schill, H. Thabe
Die periprothetische Knieinfektion – Therapiekonzept, Wertigkeit und mittelfristige Ergebnisse
Aktuelle Rheumatologie, Heft 5, 24. Jahrgang, 1999, pp 153-160 (K70)
- G.W. Baars
Knieendooprothetik: Das optimale Implantat für jeweilige Indikation finden
Orthopäde 2000 (Suppl1) 29: S1-2
- M. Zinck, R. Sellkau
Rotationsknieprothese Endo-Modell®- Geführter Oberflächenersatz mit Sti(e)
Orthopäde 2000 (Suppl1) 29: S 38-42
- M. Crowa, E. Cenna, C. Olivero
Rotating knee prosthesis – Surface or hinge replacement?
Orthopäde 2000 (Suppl1) 29: S 43-44
- J-N. Argenson, J M. Aubaniac
Total Knee arthroplasty in femorotibial instability
Orthopäde 2000.29:S 45-47, Springer Verlag 2000 (K72)
- M. von Knoch, R. Brocks, C. Siegmüller, G. Ribaric, L. Leupolt, G. von Förster
Knieflexion nach Rotationsknieendooprothese
Z. Orthop 2000; 138: 66-68 (K71)
- R.E. Windsor, K. Steinbrink
Controversies in Total Knee Replacement Two-stage exchange is the optimal treatment for an infected total knee replacement
Oxford University Press 2001 (K78)
- A.Katzer, R.Sellckau, W. Siemssen, G. von Foerster
ENDO-Modell Rotating Knee prosthesis: a functional analysis
J Orthopaed Traumatol (2002) 3:163-170
- Thomas Nau, MD, E. Pfelegerl, MD, J. Erhart, MD, and V. Vecsei, MD
Primary Total Knee Arthroplasty for Periarticular Fractures
The Journal of Arthroplasty, Vol 18, No 8, 2003 (K82)
- G. Petrou, H. Petrou, C. Tilkeridis, T. Stavrakis, T. Kapetsis, N. Kremmidas, M. Gavras
Medium-term results with a primary cemented rotating-hinge total knee replacement
A 7-TO 15-YEAR FOLLOW-UP
J Bone Joint Surg (Br), 2004; 86-B :813-17 (K84)
- M.R. Utting, J.H. Newman
Customised hinged knee replacement as a salvage procedure for failed total knee arthroplasty
The Knee 11 (2004) 475-479 (K86)
- Nayana Joshi, Antonio Navarro-Quilis
Is There a Place for Rotating-Hinge Arthroplasty in Knee Revision Surgery for Aseptic Loosening?
The Journal of Arthroplasty 2008; 23(8):1204-1210 (K94)
- M. Napp, M. Frank, M. Witt
Pathologische Fraktur des distalen Femurs bei Knie-TEP
Der Orthopäde, Band 38, Heft 10, Oktober 2009 (K96)
- Dae Kyung Bae, Sang Jun Song, Kyoung Ho Yoon, Jung Ho Noh
Long-Term Outcome of Total Knee Arthroplasty in Charcot Joint: A 10- to 22- Year Follow-Up
The Journal of Arthroplasty 2009; 24(8):1152-1156 (K98)



**Endo-Model – M
Modular Knee Prosthesis System**
with Segmental Bone Replacement Components,
Surgical Technique



**LINK PorEx (Titanium-Niob-Nitrid)
Titanium-Niobium-Nitride**
for custom-made orthopedic implants,
Materials and Coatings



Endo-Model Knee System
Literature Research

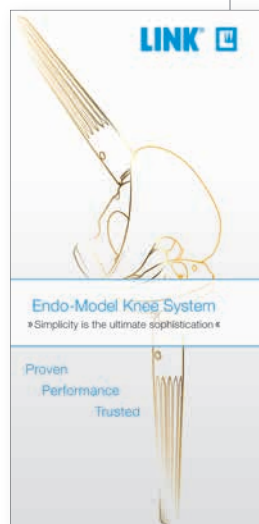

Endo-Model Knee System
Teaserflyer and Product Rationale

 For more information please register for our LINK Media Library (linkorthopaedics.com)

Please note the following regarding the use of our implants:

1. Choosing the right implant is very important.

The size and shape of the human bone determines the size and shape of the implant and also limits the load capacity. Implants are not designed to withstand unlimited physical stress. Demands should not exceed normal functional loads.

2. Correct handling of the implant is very important.

Under no circumstances should the shape of a finished implant be altered, as this shortens its life span. Our implants must not be combined with implants from other manufacturers. The instruments indicated in the Surgical Technique must be used to ensure safe implantation of the components.

3. Implants must not be reused.

Implants are supplied sterile and are intended for single use only. Used implants must not be used again.

4. After-treatment is also very important.

The patient must be informed of the limitations of the implant. The load capacity of an implant cannot compare with that of healthy bone!

5. Unless otherwise indicated, implants are supplied in sterile packaging.

Note the following conditions for storage of packaged implants:

- Avoid extreme or sudden changes in temperature.
- Sterile implants in their original, intact protective packaging may be stored in permanent buildings up until the "Use by" date indicated on the packaging.
- They must not be exposed to frost, dampness or direct sunlight, or mechanical damage.
- Implants may be stored in their original packaging for up to 5 years after the date of manufacture. The "Use by" date is indicated on the product label.
- Do not use an implant if the packaging is damaged.

6. Traceability is important.

Please use the documentation stickers provided to ensure traceability.

7. Further information on the material composition is available on request from the manufacturer.

Follow the instructions for use!

Waldemar Link GmbH & Co. KG, Hamburg

All content in this catalog, including text, pictures and data, is protected by law. Every instance of use, whether in part or in whole and which is not permitted by law, is subject to our prior consent. In particular, this applies to the reproduction, editing, translation, publishing, saving, processing, or passing on of content stored in databases or other electronic media and systems, in any manner or form. The information in the catalogs is solely intended to describe the products and does not constitute a guarantee.

The Surgical Technique described has been written to the best of our knowledge and belief, but it does not relieve the surgeon of his/her responsibility to duly consider the particularities of each individual case.

Products shown in this document may not be available in your country. The product availability is subject to the approval and/or registration regulations of the respective country. Please contact Waldemar Link GmbH & Co. KG if you have questions about the availability of LINK products in your country.

Waldemar Link GmbH & Co. KG and/or other corporate affiliated entities own, use or have applied for the following trademarks in many jurisdictions: LINK, BiMobile, SP II, Modell Lubinus, E-Dur, EndoDur, T.O.P. II, BetaCup, CombiCup PF, CombiCup SC, CombiCup R, MobileLink, C.F.P., LCU, SP-CL, LCP, MIT-H, Endo-Model, Endo-Model SL, MP, MEGASYSTEM-C, GEMINI SL, SPAR-K, LCK, Link OptiStem, HX, TiCaP, X-LINKed, PorAg, LINK PorEx, BiPorEx, PorEx-Z, TrabecuLink, Tilastan, customLINK, RescueSleeve, Stactip, VACUCAST.

Other trademarks and trade names may be used in this document to refer to either the entities claiming the marks and/or names or their products and are the property of their respective owners.

